

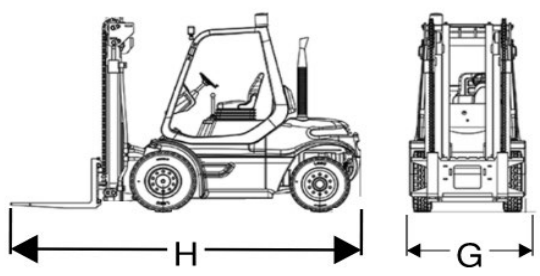

Home of the Rigger Special

MAKE: HYSTER	MODEL: 5155FT
UNIT# 100746	SERIAL# E024V01998H
MAXIMUM FORK HEIGHT.....	(A) 94"
OVERALL RAISED HEIGHT.....	(B) 142"
OVERALL LOWERED HEIGHT.....	(C) 95 1/2"
FREE FORK HEIGHT.....	(D) 0"
OVERALL RAISED HEIGHT W/BOOM	(E) _____
OVERALL LOWERED HEIGHT W/BOOM	(F) _____
TRUCK WIDTH.....	(G) 57"
TRUCK LENGTH.....	(H) 119" W/O FORKS
FORK LENGTH	OPTIONAL 8' CURRENT
FORK WIDTH	6" 44" MAX SPREAD
WEIGHT OF TRUCK	lbs# 21,410
COUNTERWEIGHT(S)	lbs# NON DETACHABLE
CAPACITY	lbs# 14,300 @ 24"
GM SPECS:	YES NO X
SIDE SHIFT:	YES X NO
FORK POSITIONERS:	YES NO
FUEL TYPE:	L.P.: X GAS: DIESEL: ELECTRIC:
HYDRAULIC BOOM:	YES NO
TIRE TYPE:	PNEUMATIC: CUSHION: X
FRONT TIRE SIZE:	28X12X22
REAR TIRE SIZE:	22X8X16
FILTERS.....	
OIL(P/N):	51036 WIX
AIR(P/N):	49742 WIX
FUEL(P/N):	LP

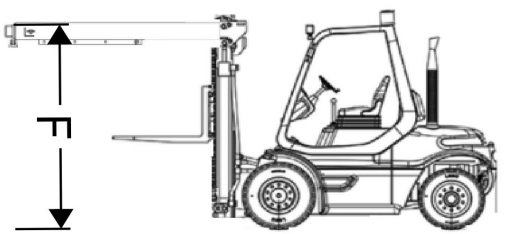
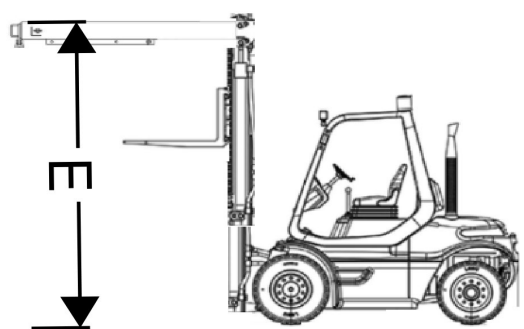
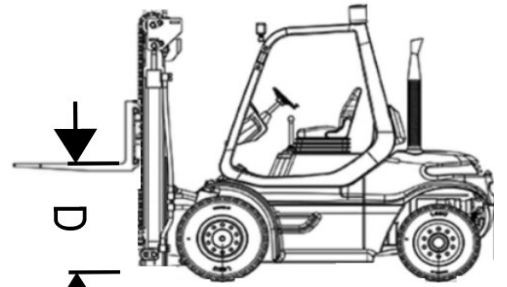
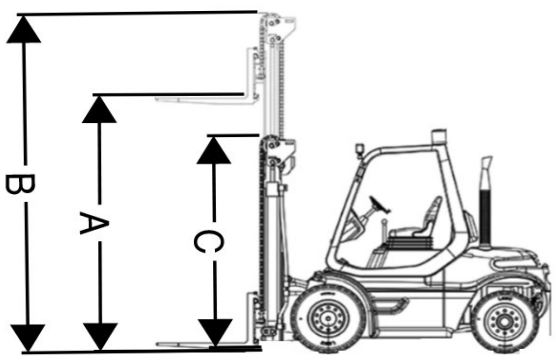

ADDITIONAL COMMENTS:

4.3 V6, ENCLOSED CAB WITH HEAT, 31P-MHD BATTERY
