

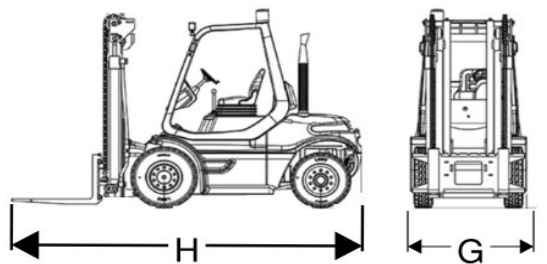

Home of the Rigger Special

MAKE: HYSTER	MODEL: S155XL2
UNIT# 100827	SERIAL# B024V01707Z
MAXIMUM FORK HEIGHT.....	(A) 132"
OVERALL RAISED HEIGHT.....	(B) 180"
OVERALL LOWERED HEIGHT.....	(C) 107"
FREE FORK HEIGHT.....	(D) _____
OVERALL RAISED HEIGHT W/BOOM	(E) _____
OVERALL LOWERED HEIGHT W/BOOM	(F) _____
TRUCK WIDTH.....	(G) 57"
TRUCK LENGTH.....	(H) 117" + FORKS
FORK LENGTH	6'
FORK WIDTH	6" 45' SPREAD
WEIGHT OF TRUCK	lbs# 20,500
COUNTERWEIGHT(S)	lbs# _____
CAPACITY	lbs# 15,500 @ 24"
GM SPECS: YES NO X	_____
SIDE SHIFT: YES NO	_____
FORK POSITIONERS: YES NO	_____
FUEL TYPE: L.P.: GAS: DIESEL: X ELECTRIC:	_____
HYDRAULIC BOOM: YES NO	_____
TIRE TYPE: PNEUMATIC CUSHION	_____
FRONT TIRE SIZE: 28X12X22	_____
REAR TIRE SIZE: 22X8X16	_____
FILTERS.....	_____
OIL(P/N): 51515 WIX	_____
AIR(P/N): 42222 WIX	_____
FUEL(P/N): 33124 WIX	_____

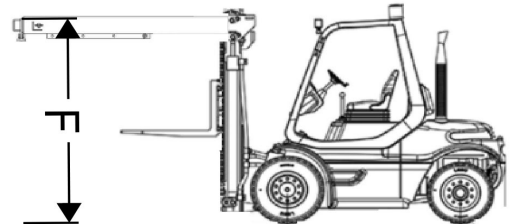
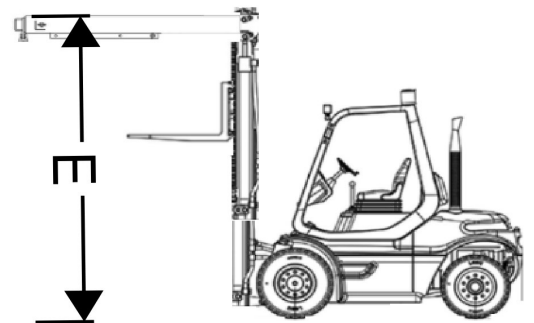
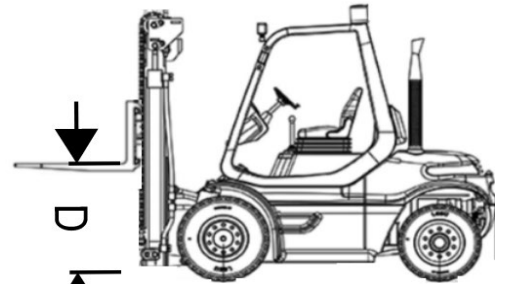
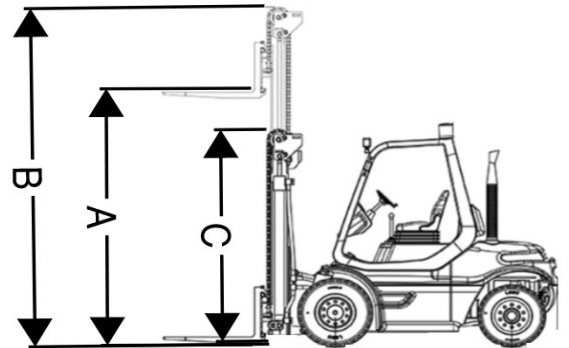

ADDITIONAL COMMENTS:

4 CYL PERKINS, NO LIGHTS/JUST STROBE, BARE BONES FORKLIFT

NO GM SPECS