

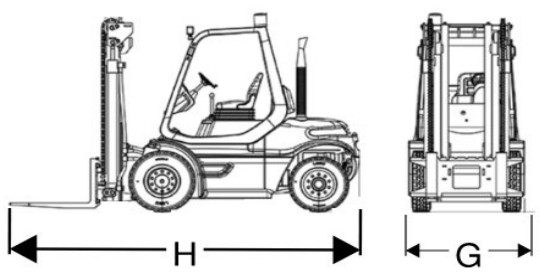

Home of the Rigger Special

MAKE: HYSTER	MODEL: S155XL
UNIT# 100839	SERIAL# B024D03117R
MAXIMUM FORK HEIGHT.....	(A) 216"
OVERALL RAISED HEIGHT.....	(B) 281"
OVERALL LOWERED HEIGHT.....	(C) 130"
FREE FORK HEIGHT.....	(D) 66 1/2"
OVERALL RAISED HEIGHT W/BOOM	(E) _____
OVERALL LOWERED HEIGHT W/BOOM	(F) _____
TRUCK WIDTH.....	(G) 56 1/2"
TRUCK LENGTH.....	(H) 115"
FORK LENGTH	6'
FORK WIDTH	_____
WEIGHT OF TRUCK	lbs# 20,900
COUNTERWEIGHT(S)	lbs# 1
CAPACITY	lbs# 15,100 @ 20"
GM SPECS:	YES NO X
SIDE SHIFT:	YES NO
FORK POSITIONERS:	YES NO
FUEL TYPE:	L.P.: GAS: DIESEL: X ELECTRIC:
HYDRAULIC BOOM:	YES NO
TIRE TYPE:	PNEUMATIC CUSHION X
FRONT TIRE SIZE:	28X12X22
REAR TIRE SIZE:	22X8X16
FILTERS.....	_____
OIL(P/N):	_____
AIR(P/N):	_____
FUEL(P/N):	_____

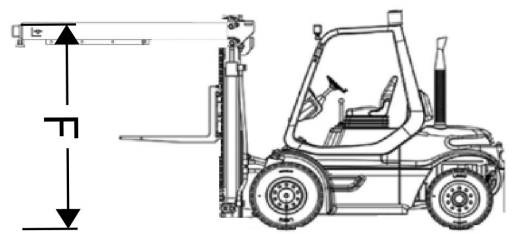
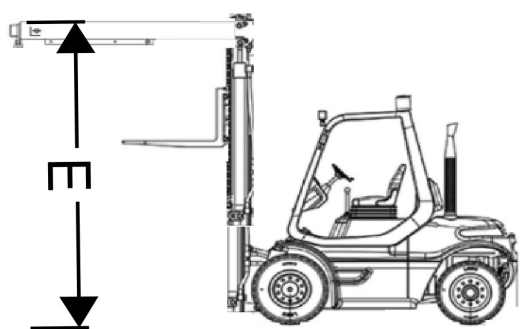
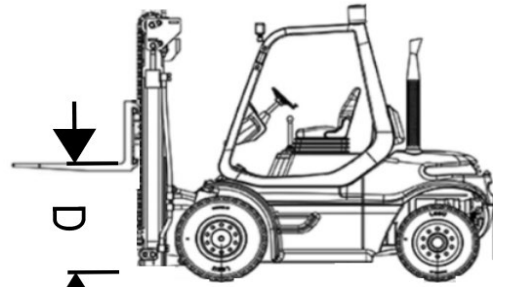
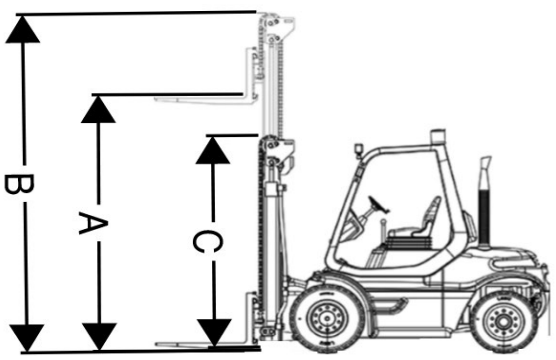

ADDITIONAL COMMENTS:
