

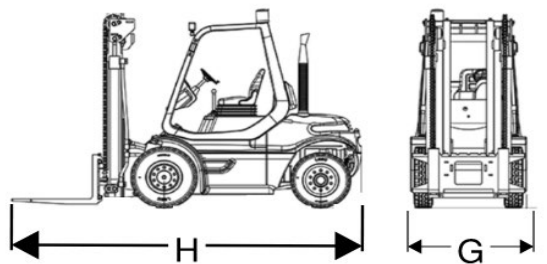

Home of the Rigger Special

MAKE: ROYAL	MODEL: 40K
UNIT# 100814	SERIAL# T121191L0
MAXIMUM FORK HEIGHT.....	(A) 94"
OVERALL RAISED HEIGHT.....	(B) 153 1/2"
OVERALL LOWERED HEIGHT.....	(C) 110"
FREE FORK HEIGHT.....	(D) 21"
OVERALL RAISED HEIGHT W/BOOM	(E) 321 1/2"
OVERALL LOWERED HEIGHT W/BOOM	(F) 113"
TRUCK WIDTH.....	(G) 70"
TRUCK LENGTH.....	(H) 146"
FORK LENGTH	8'
FORK WIDTH	8" X3 1/2" THICK
WEIGHT OF TRUCK	lbs# 46,251
COUNTERWEIGHT(S)	lbs#
CAPACITY	lbs# 40,000
GM SPECS:	YES X NO
SIDE SHIFT:	YES NO
FORK POSITIONERS:	YES NO
FUEL TYPE:	L.P.: GAS: DIESEL: ELECTRIC:
HYDRAULIC BOOM:	YES NO
TIRE TYPE:	PNEUMATIC CUSHION X
FRONT TIRE SIZE:	28X10X22
REAR TIRE SIZE:	22X10X16
FILTERS.....	
OIL(P/N):	51085 WIX
AIR(P/N):	42144 WIX
FUEL(P/N):	

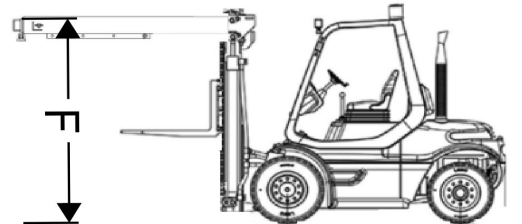
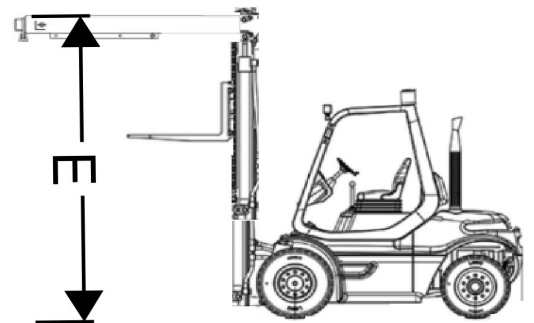
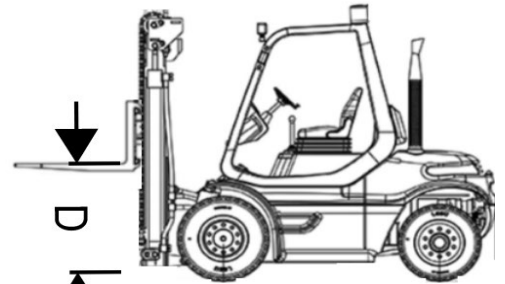
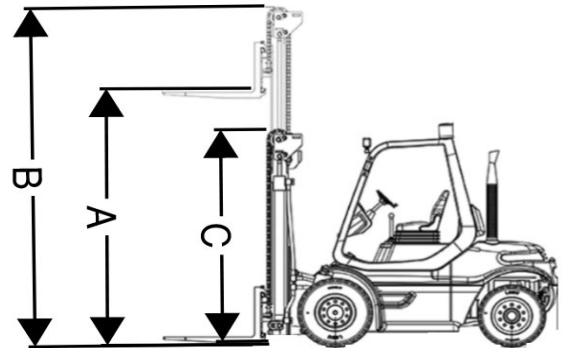

ADDITIONAL COMMENTS:

MANUAL PIN, ENGINE MODEL K1161157

SERIAL #LH360-1-481EC, CHRYSLER 360, AIR BRAKES