

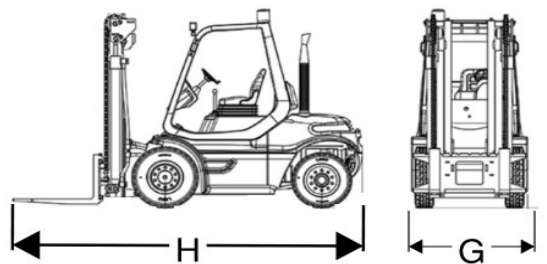

Home of the Rigger Special

MAKE: TAYLOR	MODEL: TCH300M
UNIT# 112528	SERIAL# S-D2-19801
MAXIMUM FORK HEIGHT.....	(A) 109"
OVERALL RAISED HEIGHT.....	(B) 164"
OVERALL LOWERED HEIGHT.....	(C) 111"
FREE FORK HEIGHT.....	(D) _____
OVERALL RAISED HEIGHT W/BOOM	(E) 296"
OVERALL LOWERED HEIGHT W/BOOM	(F) 111"
TRUCK WIDTH.....	(G) 74"
TRUCK LENGTH.....	(H) 156 1/2" +FORKS 92" LONG, 7 7/8" WIDE, 3 1/2" THICK
FORK LENGTH	_____
FORK WIDTH	68" MAX, 20" MIN
WEIGHT OF TRUCK	lbs# 52,870
COUNTERWEIGHT(S)	lbs# PERMANENT
CAPACITY	lbs# 30 @ 36"
GM SPECS:	YES X NO _____
SIDE SHIFT:	YES NO _____
FORK POSITIONERS:	YES NO _____
FUEL TYPE:	L.P.: X GAS: DIESEL: ELECTRIC: _____
HYDRAULIC BOOM:	YES NO _____
TIRE TYPE:	PNEUMATIC CUSHION X _____
FRONT TIRE SIZE:	28X10X22 (2 PER SIDE) _____
REAR TIRE SIZE:	22X10X16 _____
FILTERS.....	_____
OIL(P/N):	_____
AIR(P/N):	_____
FUEL(P/N):	_____

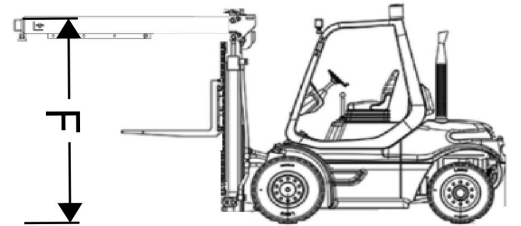
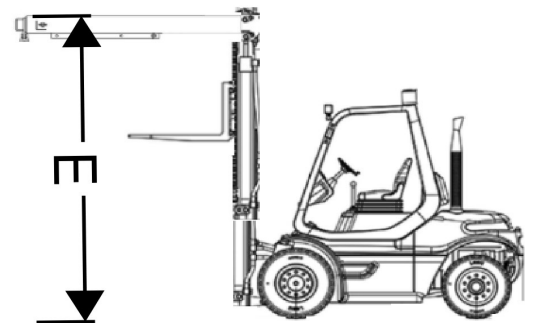
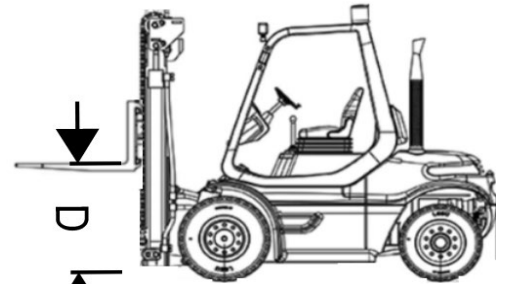
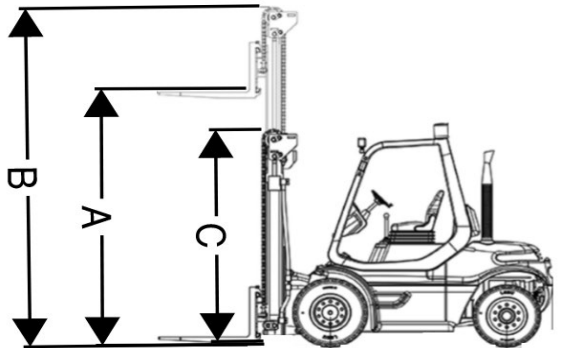

ADDITIONAL COMMENTS:
CHRYSLER 318, 16 HOLE FIBER GEAR

